

!WARNING!
SPACE BETWEEN DOOR AND HOISTWAY
MUST NOT EXCEED 3"

INTERLOCKS CONFORMING TO ASME A17.1
MUST BE INSTALLED AND ADJUSTED PER
THE MANUFACTURER'S INSTRUCTIONS.

**!FAILURE TO COMPLY
MAY RESULT IN SERIOUS
INJURY OR DEATH!**

NOTE:
LEAVE ROUGH OPENING MIN
14" WIDER & 14" HIGHER THAN
CLEAR OPENING, AS SHOWN.

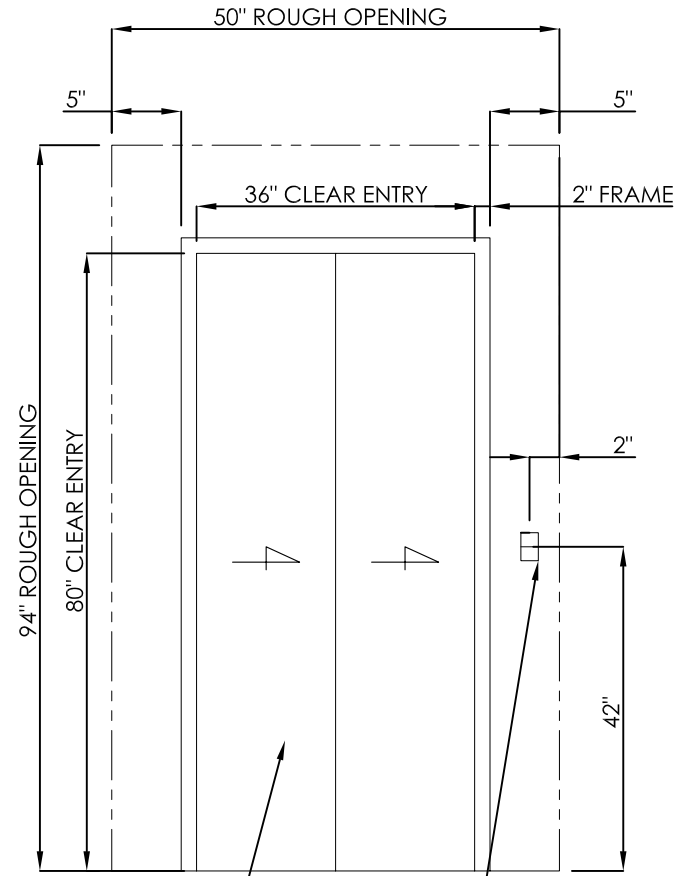

2 SPD SIDESLIDE
ENTRANCE

2 1/4" WIDE X 3 3/4" HIGH
3" DEEP CUTOUT ON
ALL FLOORS FOR CALL
BUTTON BOX

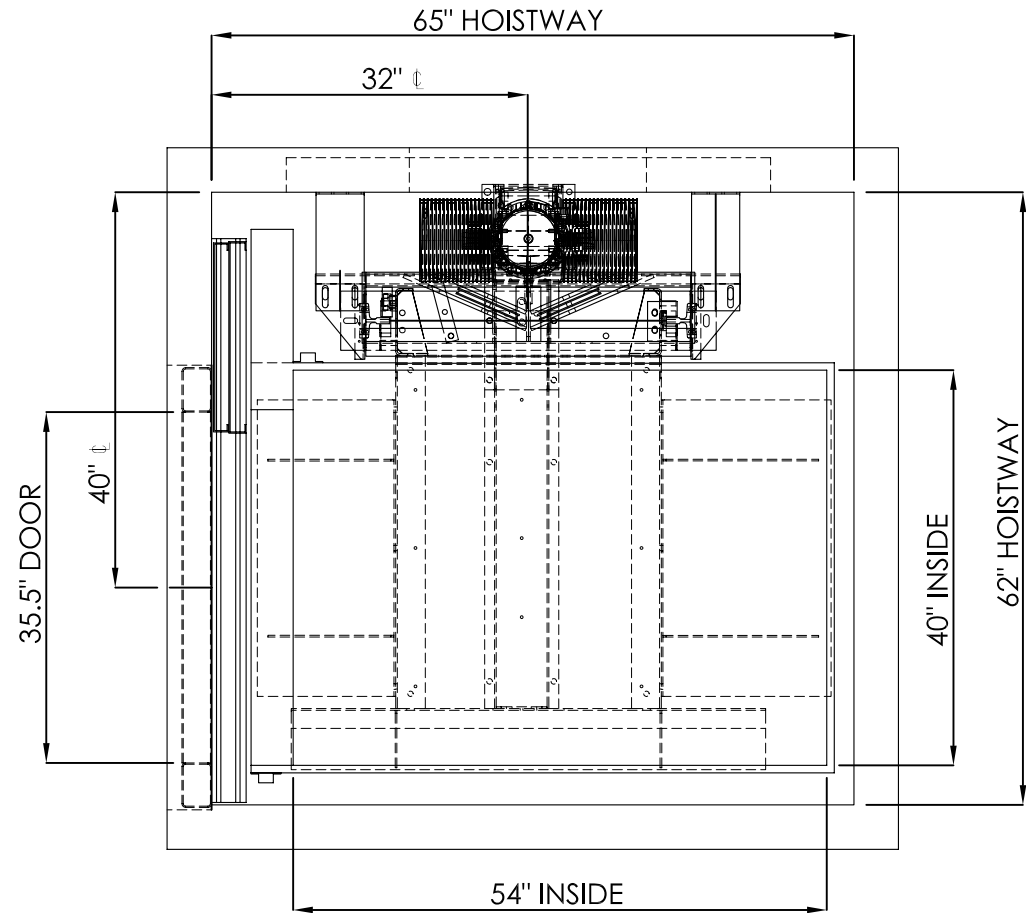

RAIL WEIGHT: 8 lbs/ft	
RAIL FORCES	
*R1 (Fx)	1075 lbs
*R2 (Fy)	358 lbs
R3 (Fz)	2500 lbs

SIZE	Nationwide Lifts www.elevators.com	
A	P: 888-695-4387	E: info@elevators.com
PART NO. 40 X 54, 1L		
SHEET 1 OF 3		
DESCRIPTION: SLIDING DOORS, BASEMENT DRUM		

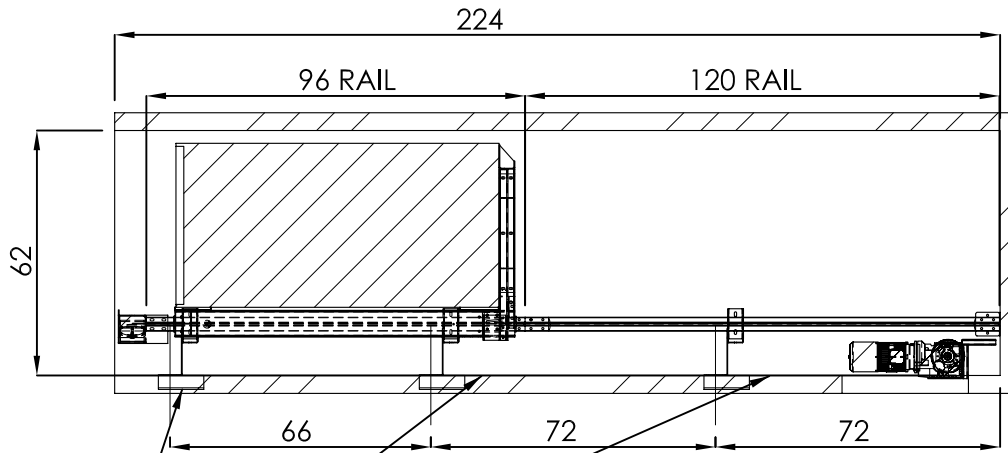

BRACKET LOCATIONS MAY VARY
ACCORDING TO TRAVEL

PROVIDE WALL CONSTRUCTION
SUITABLE FOR ATTACHMENT OF
RAIL BRACKETS AT SHOWN ELEVATION.
MUST BE CAPABLE OF 300LB PULLOUT
LOADING WITH MAX DEFLECTION OF 1/8".

SPREADER BRACKETS
FASTEN WITH LAG SCREWS
2 PLACES PER SIDE BRACKET

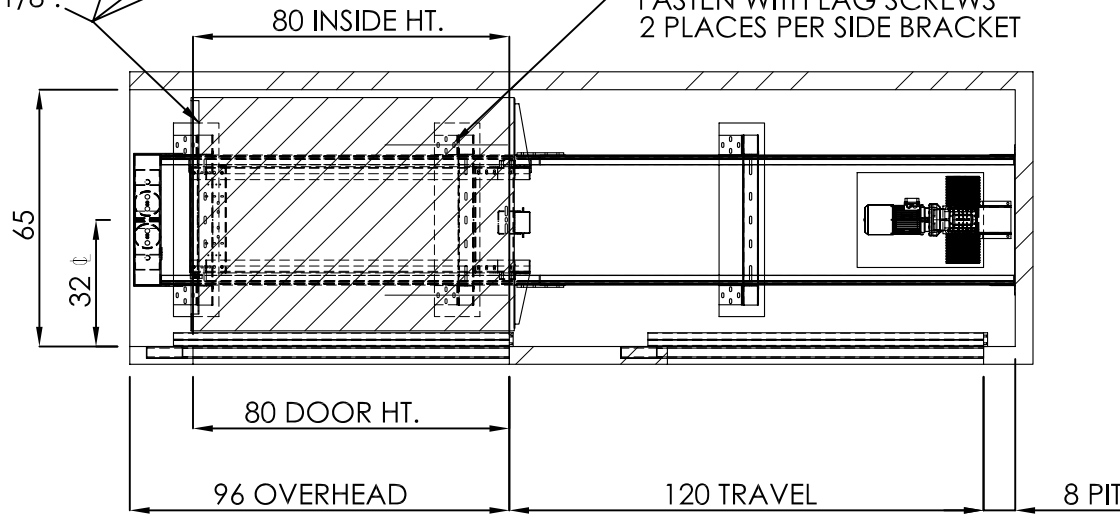

SIZE	 Nationwide Lifts www.elevators.com P: 888-695-4387 E: info@elevators.com
A	
PART NO.	40 X 54, 1L
SHEET 2 OF 3	
DESCRIPTION:	SLIDING DOORS, BASEMENT DRUM

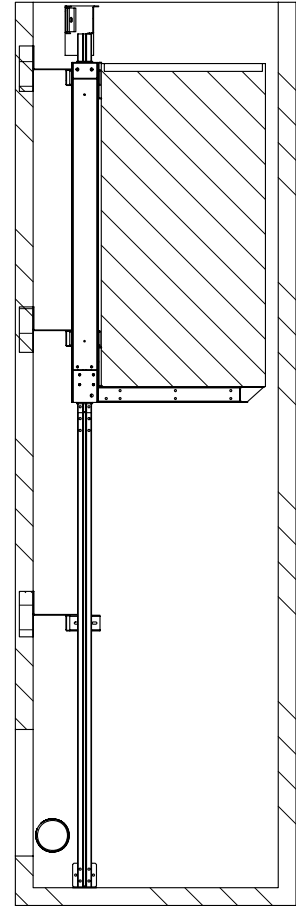
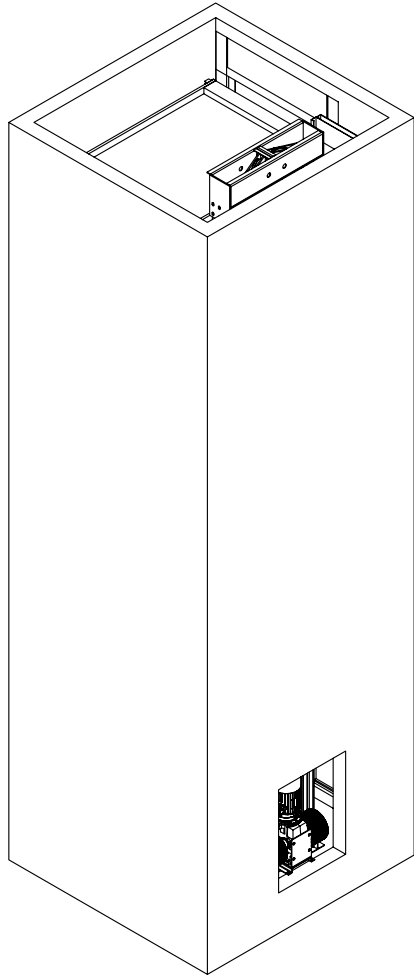
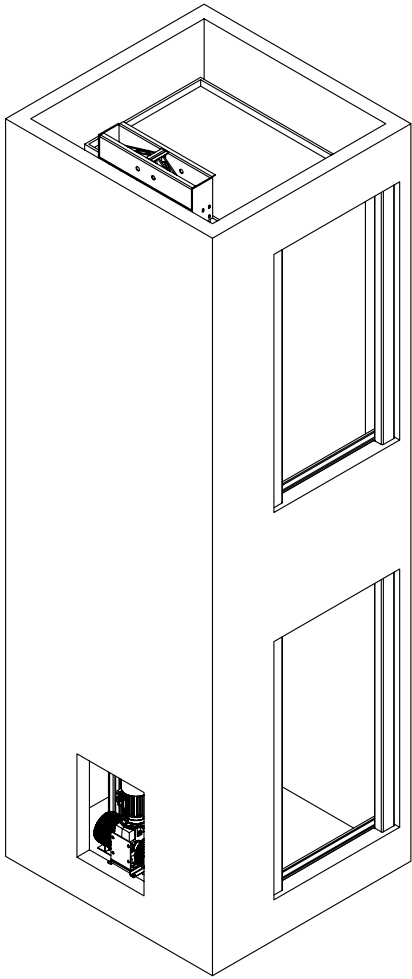

5



4

3

2

1

SIZE	 Nationwide Lifts www.elevators.com P: 888-695-4387 E: info@elevators.com
A	
PART NO.	40 X 54, 1L SHEET 3 OF 3 DESCRIPTION: SLIDING DOORS, BASEMENT DRUM